



EVERLIGHT ELECTRONICS CO.,LTD.

Device Number : CDLE-026-119 REV.: 2

3.0mm Round Type LED Lamps

PART NO. : 264-7IT

ECN: _____ Page: 1/4

■ Features :

- Choice of various viewing angles
- Available on tape and reel.
- Reliable and robust

■ Descriptions :

- The series is specially designed for applications requiring higher brightness
- The led lamps are available with different colors, intensities,

■ Applications :

- TV set
- Monitor
- Telephone
- Computer

■ Package Dimensions:

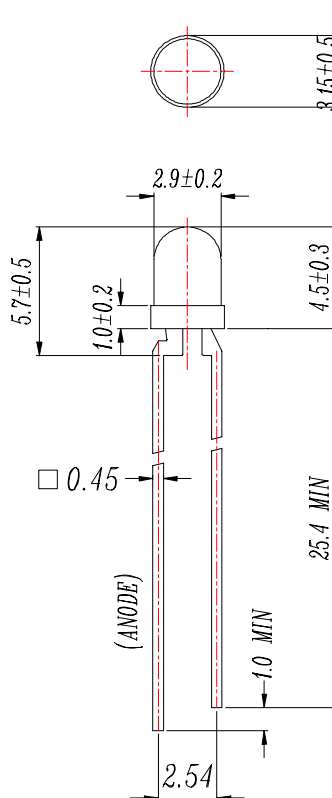

■ Notes :

1. All dimensions are in millimeters.
2. An epoxy meniscus may extend about 1.5mm(0.059") down to the lead.
3. Tolerances unless Dimension ± 0.25 mm.

PART NO.	Chip		Lens Color
	Material	Emitted Color	
264-7IT	GaAsP/GaP	Hi-Eff Red	Red Trans

Office : 7C Building, Lian Hua Port Industrial District, Lian Hua Shan
 Bonded Processing Zone Pan Yu, Guang Zhou, China

TEL. : (020)84860913,84860914

FAX : (020)84860600

http : //www.everlight.com



EVERLIGHT ELECTRONICS CO.,LTD.

Device Number : CDLE-026-119 REV.: 2

3.0mm Round Type LED Lamps

PART NO. : 264-7IT ECN : Page: 2/4

■ Absolute Maximum Ratings at Ta = 25°C

Parameter	Symbol	Rating	Unit
Forward Current	I _F	30	mA
Operating Temperature	T _{opr}	-40 to +85	°C
Storage Temperature	T _{stg}	-40 to +100	°C
Soldering Temperature	T _{sol}	260 ± 5	°C
Power Dissipation	P _d	100	mW
Peak Forward Current(Duty 1/10 @ 1KHz)	I _{F(Peak)}	160	mA
Reverse Voltage	V _R	5	V

■ Electronic Optical Characteristics :

Parameter	Symbol	Min.	Typ.	Max.	Unit	Condition
Luminous Intensity	I _v	6.3	16.0	/	mcd	I _F = 10 mA
Viewing Angle	2θ 1/2	/	40	/	deg	I _F = 20 mA
Peak Wavelength	λ _p	/	635	/	nm	I _F = 20 mA
Dominant Wavelength	λ _d	/	625	/	nm	I _F = 20 mA
Spectrum Radiation Bandwidth	Δλ	/	45	/	nm	I _F = 20 mA
Forward Voltage	V _F	1.7	2.0	2.4	V	I _F = 20 mA
Reverse Current	I _R	/	/	10	μA	V _R = 5 V



EVERLIGHT ELECTRONICS CO.,LTD.

Device Number : CDLE-026-119 REV.: 2

3.0mm Round Type LED Lamps

PART NO. : 264-7IT

ECN : _____ Page: 3/4

■ Typical Electro-Optical Characteristic Curves:

< I >

